



KONICA MINOLTA



U&S
Digital

AccurioPress
C14000/C12000

**SET YOUR
BUSINESS FREE
WITH EFFORTLESS
SIMPLICITY**
RETHINK EFFICIENCY

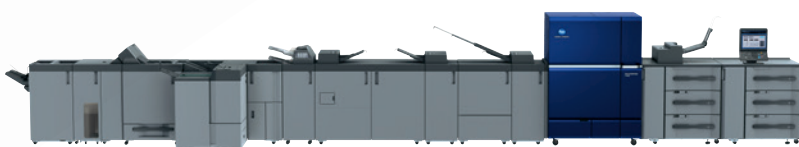

Giving Shape to Ideas

SMART FACTORY PRINTING

The digital revolution continues; and in the outstanding development history of Production Printing products at Konica Minolta, the AccurioPress C14000 and C12000 are the masterpieces of the next generation. The new flagship models distinguish themselves with unprecedented print quality, amazing media flexibility and the highest degree of automation. With their speed of up to 140 ppm (up to 120 ppm for the C12000), the AccurioPress C14000 and C12000 simply do the job, day after day – printing with consistency, reliability, ease and efficiency on a wide array of media.

Grow your business

We place great importance on empowering you to grow your business with our solutions. Our new system can for example help you with its extensive variety of supported media, from thin to thick paper (up to 450 g/m²), embossed paper, envelopes, as well as polyester and cut-sheet labels – to name but a few. It prints on long sheets of up to 1300 mm, or 900 mm in duplex.

Boost your operational efficiency

Our new generation of true production systems has been designed to increase the uptime of your press and print more in less time. Their range of new features lets you produce more higher-value print products faster. With the Intelligent Quality Care Unit, you achieve the desired print quality every time, job by job.

Maximise your investment

We want to make sure that you get the most out of your press – that's why we have reduced the setup time drastically giving you maximum uptime. Combine your press with various inline finishing capabilities and produce more than ever, with idle times kept to a minimum.

Improve customer loyalty

With the AccurioPress C14000 series automatically adjusting the print quality on the fly, you can be sure to always produce exactly the quality that you and your customers expect – from page 1 to page 100 or 1000, today and again tomorrow. The enhanced Auto Inspection Technology guarantees that only impeccable prints leave your shop – all making sure that your customers will come back to you but your products won't!

Automation and time savings like never before

The IQ-501 provides extensive automation for image position and registration on the one and colour control on the other hand. Furthermore the new media sensor automatically detects the type, weight, thickness and surface of each paper quality proposing the appropriate substrate from the paper catalogue – all designed to reduce operator time and print wastage while increasing productivity.



INNOVATE PRINT RETHINK TECHNOLOGY



Intelligent Quality Care

The IQ-501 Intelligent Quality Care Unit takes color consistency and registration accuracy to the next level. With highly automated image registration and color control, a closed-loop system that constantly monitors and adjusts printed output, and automated color calibration and profiling, IQ-501 delivers streamlined operator time, reduced print waste, and industry-leading productivity!

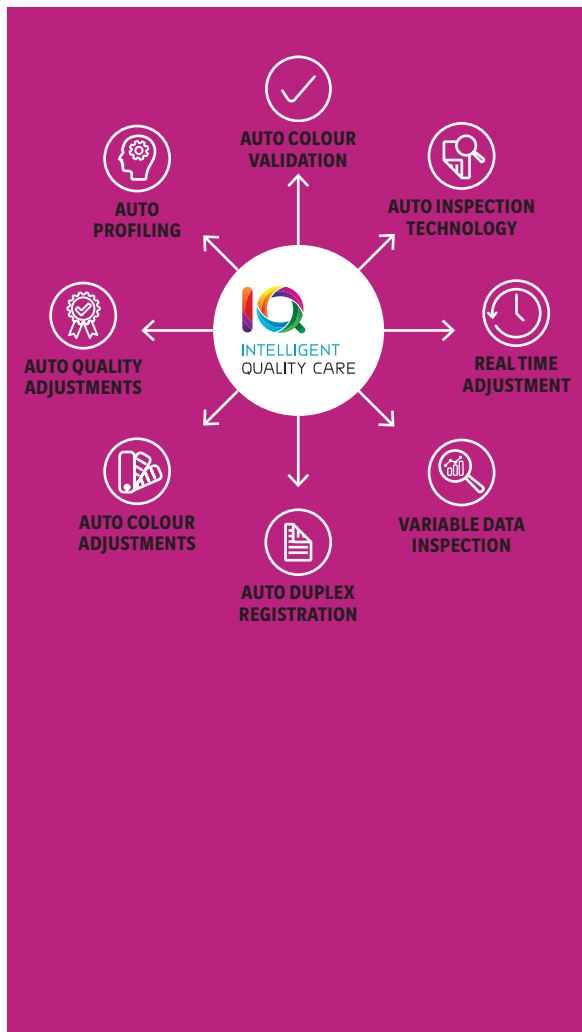

Simitri[®] V

Simitri[®] V Toner

Konica Minolta's innovative Toner technology Simitri[®] V gives superb print quality and an offset matte finish. Furthermore it supports the high productivity of AccurioPress C14000 series and it requires a lower fusing temperature which reduces the energy consumption of the system and the impact of the printing process on the paper. Simitri V was designed to easily follow the surface of the paper or substrate to guarantee best possible print quality on embossed, structured or recycled materials.

S.E.A.D. X Image Processing

Konica Minolta's own advanced colour processing technology of the fifth generation is called S.E.A.D. X, which stands for "Screen-Enhancing Active Digital Process", and combines an array of technical innovations to guarantee truly exceptional colour reproduction at top speed.

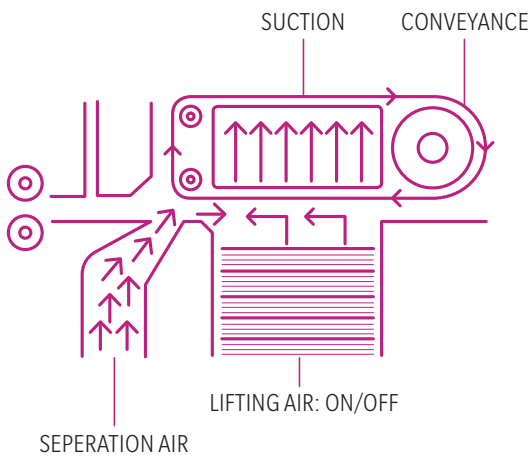

Vacuum paper feeding

It is essential for high-volume printers to feed each and every sheet smoothly and precisely through the digital press. To ensure this, Konica Minolta offers professional and intelligent paper feeding for all formats up to 900 mm length that builds upon proven concepts, including a combination of air separation of sheets and suction/vacuum feeding. This ensures smooth paper processing throughout the printing system. For efficient printing on offset preprinted and coated stock as well as under high humidity conditions, an optional heating unit can be added to enhance this precise technology further.

Media Detection Sensor

The Media Detection Sensor automatically recognises the paper you are using, it will measure the thickness, the surface and the weight of the paper and with the information it present the user paper profile suggestion from the list of available papers in the paper catalogue, about 300 paper profiles are

pre-registered in the catalogue making sure always finding a good match. No matter if you deal with unknown paper you got by your customers or with unexperienced use don't know how to set up paper the Media Detection Sensor help you reduce waste and time to find the right settings.

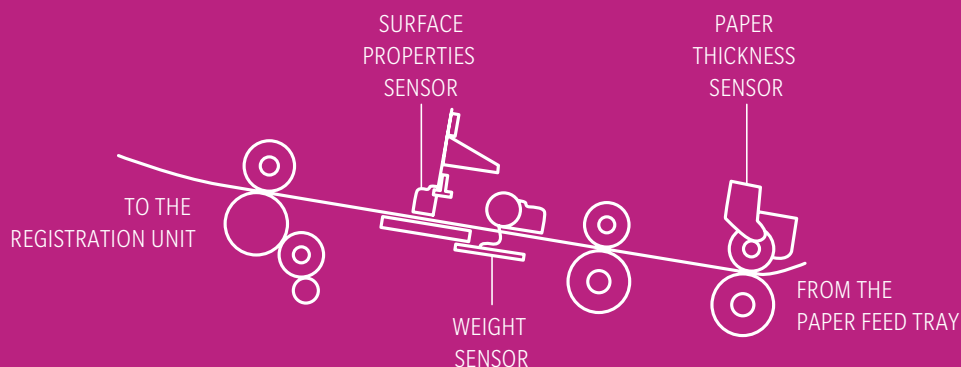





STATE-OF-THE-ART- PRINT-SERVER RETHINK PRODUCTION PRINTING

IC-610 KONICA MINOLTA OWN CONTROLLER

The Konica Minolta IC-610 print controller comes with powerful workflow benefits – including 2,400 x 3,600 equiv. dpi printing at full rated engine speed, high-speed RIP processing, enhanced accuracy in colour reproduction, various colour management functions as well as full compatibility with print engine on-board job control and editing functions.

IC-318 EFI FIERY CONTROLLER

Reduce labour costs, cut turnaround times, and minimize errors and paper waste with the advanced job management and workflow automation that the Fiery® IC-318 provides. Streamline your job layout with the Fiery's instant visual preview and advanced make ready capabilities. What's more, supporting industry-leading variable data printing (VDP) formats, the Fiery also produces personalized short-run jobs profitably.

IC-319 EFI FIERY CONTROLLER

The top-of-the-line Fiery® IC-319 will improve your bottom line with best-in-class processing, outstanding colour and time-saving workflows. If you want the best out-of-the-box colour consistency and accuracy with powerful colour matching, profiling, and automated calibration, look no further! With EFI™ management information systems and web-to-print solutions, the IC-319 eliminates touch points and optimizes production; plus it integrates with industry-leading prepress workflow solutions.

IC-316 CREO CONTROLLER

The Creo® IC-316 external print controller supports perfect variable data printing integration and is the ideal choice for hybrid prepress workflows. Beyond that, the Creo features advanced spot colour profiling, a complete Pantone GOE library, Remote Site Manager status tracking, JDF connectivity, Creo job ticket software, and much more.





STREAMLINE YOUR PRODUCTION

RETHINK YOUR WORKFLOW

Evolving from our expertise in precision technologies and more than 80 years of experience in the printing and imaging industries, AccurioPro reflects our commitment to developing market-shaping technology with functionality that enables your business to grow. AccurioPro, Konica Minolta's suite of digital solutions for professional printing, is one of the industry's most versatile and powerful tools to optimise print production operations and workflows.

For all printing companies looking to integrate their printing as well as businesses that use digital printing to produce their own in-house publications and promotional materials, AccurioPro boosts speed and

efficiency, expands capabilities and services, and reduces the need for operational manpower – all of which will help improve your profitability!

The comprehensive suite of features that AccurioPro offers includes centralised management, software for automated workflow processing, colour management, seamless integration of different printing technologies and full connectivity of all Konica Minolta printing systems used from input to output.

AccurioPro POSSIBILITIES

RETHINK YOUR WORKFLOW

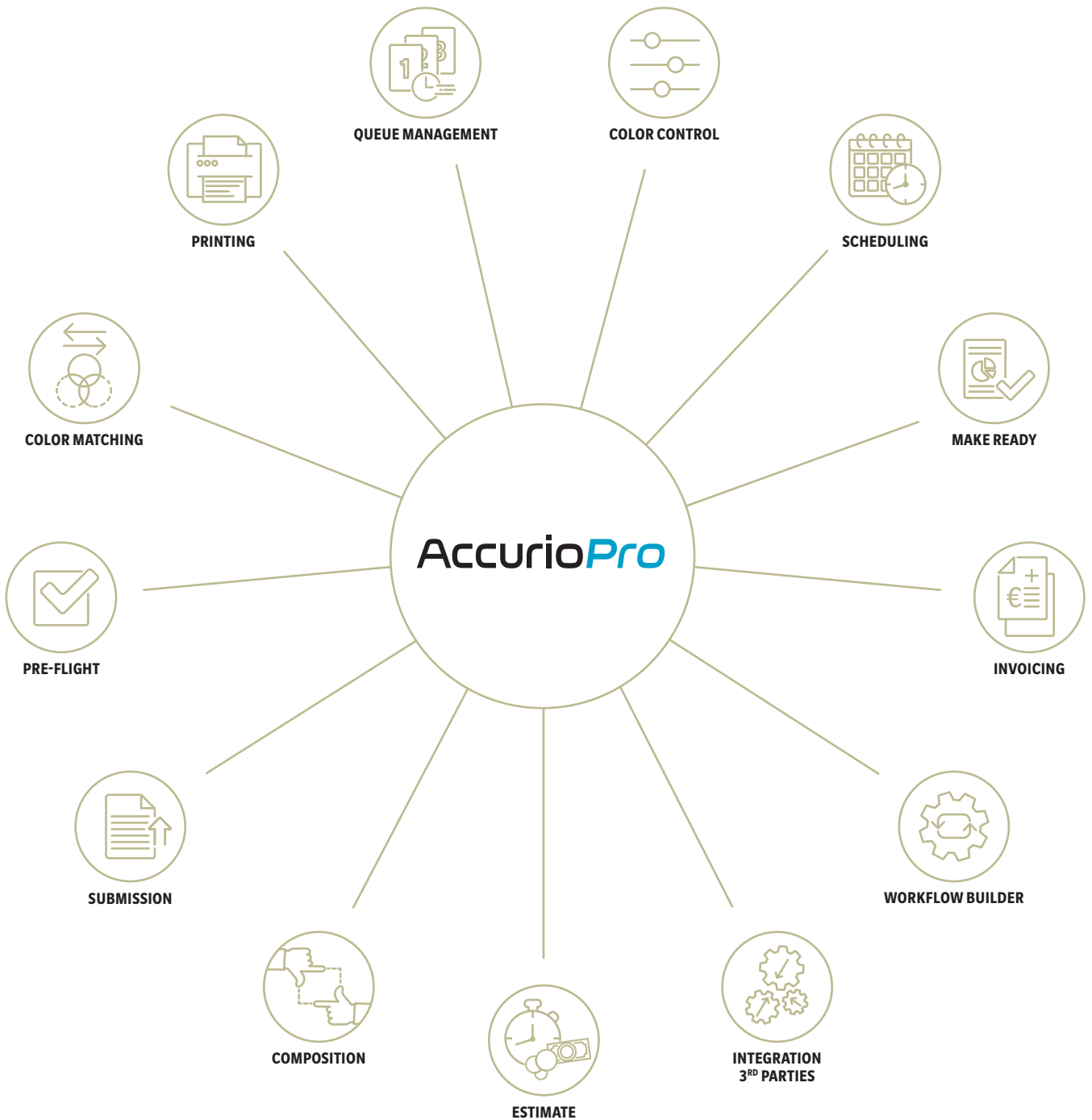

YOUR ADVANTAGES WITH THE AccurioPress C14000/C12000

RETHINK PRODUCTION PRINTING

READY-MADE PRINT PRODUCTS

- 50-sheet booklet making with front trimming and optional creasing, slitting and spine corner forming
- Perfect binding for books of up to 30 mm
- 100-sheet stapling with cutting mechanism
- 102-sheet auto ring binding
- Automated inline business card and postcard cutting
- Full bleed banners, A3 and A4 posters

DURABLE PERFORMANCE

AccurioPress C14000

- Duty Cycle 2.5 million prints
- Up to 140 A4 pages per minute
- Up to 80 A3 pages per minute

AccurioPress C12000

- Duty Cycle 2.2 million prints
- Up to 120 A4 pages per minute
- Up to 69 A3 pages per minute

HIGHEST RELIABILITY

- Long-life platform, long-lasting parts and consumables
- Accurate front to back registration
- Fusing-rolling mechanism
- For prints with maximum efficiency
- For lucrative short-run printing

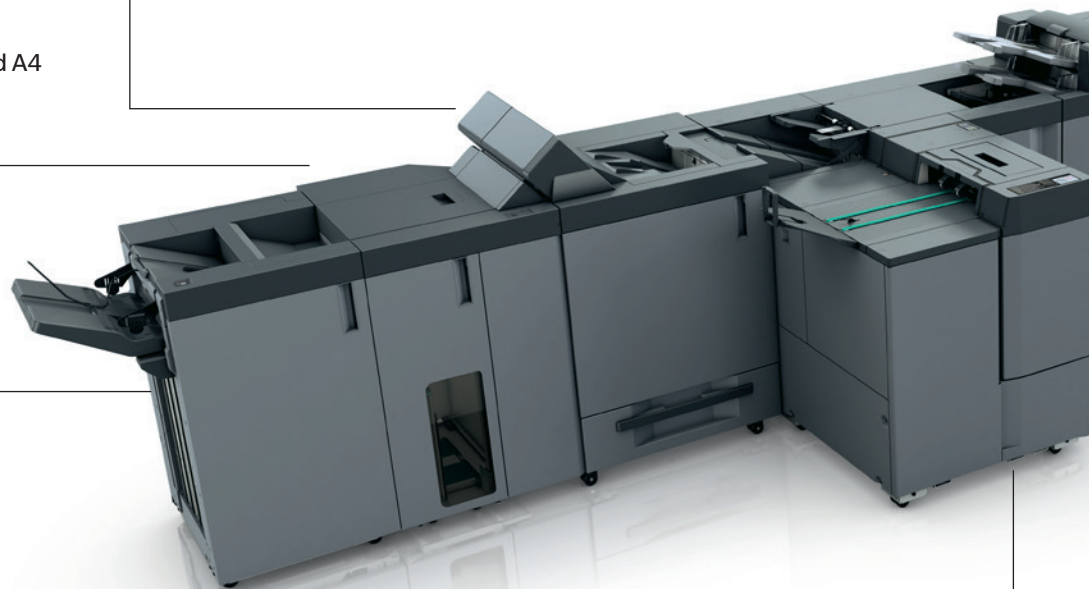

GEARED-UP FINISHING

- Multi (GBC) punching and 2- & 4-hole punching
- 6 different types of folding
- 3rd-party Products
- Large-capacity stacking
- 2 Perforations in feed direction, 5 Perforations in Cross feed direction
- Up to 5 Creases downwards or upwards

SIMPLY EFFICIENT

- Automated engine linearisation
- Automated duplex registration
- Automated profiling
- Real-time adjustments
- Purge function

HIGH-END PRINT CONTROL

- Flexible choice of controller technology: EFI®, CREO® or proprietary Konica Minolta controller
- Integration into hybrid workflows

EASE OF USE

- Simple paper catalogue settings
- Operator Replaceable Parts
- Auto Inspection Technology

PERFECT IMAGE QUALITY

- S.E.A.D. X
2,400 x 3,600 equiv. dpi x 8bit
- Simitri V toner technology
- Image density control technology

COMPREHENSIVE MEDIA PROCESSING

- Up to 450 g/m² paper weight in simplex and duplex printing
- Long sheet size of up to 1,300mm (duplex up to 900mm)
- Reliable thin paper feeding through air-blow fusing separation
- Envelope printing
- Embossed paper support
- Optional inter-cooler curl eliminator

SOPHISTICATED MEDIA HANDLING

- Automatic media recognition
- Air-suction feeding technology
- Up to 14,140 sheets paper input capacity
- Up to 10 paper input trays
- Up to 2,300 sheets paper input for long sheets (up to 900mm)



FINISHING & FUNCTIONS



Letter fold



2/4 hole Punching



Two-point stapling



Corner stapling



Stacking



Booklet



Trimming

Open stacker
OT-512



Ring binding unit
MB-200 Max Finisher



Staple finisher
FS-541



Booklet making unit
SD-513



Stacking unit
LS-507



Folding and punching unit
FD-503



Perfect binding unit
PB-503



Booklet making unit
SD-506



Trimming unit
TU-510



Booklet making unit
Plockmatic SD-350/500



Booklet making unit
PSQ-224/160



Ring binding unit
GBC G1



































Multi punching unit
GBC G2



Multi purpose stacker
Plockmatic MPS-130



	 Creasing	 Slitting	 Perforation	 Square-folding	 Multi Letter fold-In	 Post Insertion	 Perfect Binding	 Wire-binding	 Ring-binding	 Multi-punching	
											ENTRY
											
											MID
											
											
											
											HIGH
											
											
											

THE PERFECT MATCH FOR ANY REQUIREMENT

RETHINK EFFICIENCY

You are looking for a printing system that can be configured exactly to your individual requirements? You have found it in the AccurioPress C14000 series: Choose from a wide range of fully automatized finishing options to create ready-made print products and save a lot of time. Or go for full production speed and utilize your existing offline finishing capabilities for long print runs. The following sample configurations are just three of many individual options to help you find your “Perfect Match”.



PERFORMER

The Performer offers maximum speed and reliability with highest paper input and output capacity. It provides unattended long-run production delivering unparalleled and error-free print quality.

The Performer is your ideal solution for environments with existing offline finishing equipment.



ALL-ROUNDER

The All-rounder addresses flexible high-volume production demands in combination with fully automated short-run printing and finishing. It gives you the option to decide case by case how to produce the job at hand most efficiently.

The All-rounder is perfectly suited to production environments combining the strengths of both offline and inline finishing.

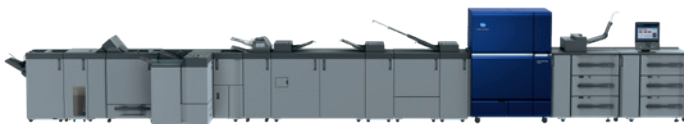

SPECIALIST

The Specialist is the perfect match for the automatic production of defined, ready-made print products. By compromising on the overall engine performance, operator interventions are kept to a minimum and production steps, errors and waste are reduced.

The Specialist is great in locations without offline finishing and wherever manual operation should be minimized.

10 GOOD REASONS FOR AccurioPress C14000 SERIES



1. SIMPLY EFFICIENT

with Media Detection Sensor, Intelligent Quality Care and many unique inline finishing options.



2. PERFECT IMAGE QUALITY

with Konica Minolta's very own Imaging Technology and Toner development.



5. MORE JOBS IN THE SHOP

Ready-made print products and geared up finishing with a variety of inline solutions.



6. EASE OF USE

even novice operator will get very good and repeatable results with just a finger tip.



3. HIGHEST RELIABILITY

built on platform to manage up to 2.5 million prints a month.

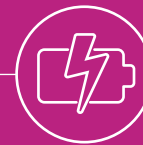

4. DURABLE PERFORMANCE

Same speed on all medias from 52 to 450g/m².



7. GROW YOUR BUSINESS

with a variety of supported medias like long sheets, banners, embossed, envelopes, recycled and polyester films.



8. INCREASE UPTIME

with automated and time reduced setup times.



9. IMPROVE YOUR CUSTOMER LOYALTY

auto quality measure to print the expected.



10. SHORT TURNAROUNDS

with automated quality control and inspection on the fly.





TAKE LEADERSHIP AND RESPONSIBILITY

RETHINK TOMORROWS BUSINESS

MADE YOUR BUSINESS

Commercial printers

Growing your business and getting the maximum out of your investment is what the AccurioPress C14000 series promises. The high speed, high productivity and high uptime help you achieve shortest turnaround times. Combined with great media flexibility with stocks of up to 450 g/m², banners, envelopes and structured papers, you further enhance the offerings of your print shop. Colour quality issues are a thing of the past, as these presses offer a wide range of tools to control and adjust themselves; on top an inspection system can be applied to make sure that from now on, only impeccable prints will leave your shop.

CRDs

AccurioPress C14000 / C12000 support the highest degree of automation and yet also ensure high-level quality. Professional inline finishing produces ready-made print products at the click of a finger; and the Intelligent Quality Care Unit makes sure that the print quality is automatically set up, monitored and corrected. Their versatile media flexibility and high productivity make AccurioPress C14000 and C12000 a solid and lucrative investment for the future.

DESIGN FOR OUR PLANET

Konica Minolta promotes sustainable development and integrates environmental and social perspectives into its business strategies. You can rely on Konica Minolta products to underpin your green strategy to build your business.

Committed to help prevent global warming, Konica Minolta strives to reduce CO₂ emissions during product manufacture, product distribution, at the sales stage, and during product use – with even stricter targets than demanded by the Kyoto Protocol. Enabling carbon neutrality, Konica Minolta offers its customers the offset of unavoidable CO₂ emissions for production printing. Together with the experts from Climate Partner, Konica Minolta proposes a new and profound eco concept for our professional production presses.





CONTROLLER AND OPTIONS

RETHINK THE NEEDS

FIERY IMAGE CONTROLLER IC-319

Architecture	External
OS	Windows 10
CPU	Intel® Xeon 5118
Clock speed	2.3 GHz
RAM std	32 GB
HDD	4.5 TB
Page-description language	Adobe PostScript 3; PDF v1.7; APPE v5; PDF/VT-1/-2 v3; PDF/X1a,3,4; PPML v3.0; PCL; Creo VPS
Applicable OS	Windows 8.1/10; Windows Server 2012/R2/2016/2019; Mac OS X 10.11-14

FIERY IMAGE CONTROLLER IC-318

Architecture	External
OS	Windows 10
CPU	Intel i7-6700
Clock speed	3.2 GHz
RAM std	16 GB
HDD	1 TB
Page-description language	Adobe PostScript 3; PDF v1.7; APPE v5; PDF/VT-1/-2 v3; PDF/X1a,3,4; PPML v3.0; PCL; Creo VPS
Applicable OS	Windows 8.1/10; Windows Server 2012/R2/2016/2019; Mac OS X 10.11-14

CREO IMAGE CONTROLLER IC-316

Architecture	External
OS	Windows 10
CPU	Intel i7-8700
Clock speed	3.2 GHz
RAM std	20 GB
HDD	8 TB
Page-description language	Adobe PostScript 3; PDF v1.7; APPE v4.9; PDF/VT-1/-2; PDF/X1a,3,4; PPML v2.2; Creo VPS; AFP; IPDS; JPEG; TIFF (v6, 1bit)
Applicable OS	Windows 8.1/10; Windows Server 2012/R2/2016/2019; Mac OS X 10.11-14

KONICA MINOLTA IMAGE CONTROLLER IC-610

Architecture	Internal
OS	Linux
CPU	Intel Core i7-6700
Clock speed	3.4 GHz
RAM std	16 GB
HDD	3 TB
Page-description language	Adobe PostScript 3; PDF v1.7; APPE v4.6; PDF-VT; TIFF (v6); PPML v2.2; PCL 5c/XL
Applicable OS	Windows 8.1/10; Windows Server 2012/R2/2016/2019; Mac OS X 10.11-14

OPTIONS

KM image controller	IC-610
EFI external image controller	IC-318
EFI external image controller	IC-319
CREO external image controller	IC-316
Paper Feeder Unit	PF-712
Paper Feeder Unit with Scanner	PF-713
Paper Feeder Unit	PF-812
Dehumidifier Heater	HT-506
Multi Bypass Tray	MB-511
Conveyance Unit	RU-518m
Humidifier	HM-103
Intelligent Quality Optimizer	IQ-501
Purge Unit	RU-702
Auto Inspection Unit	UK-301
Envelope Fusing Unit	EF-106
Output Tray Unit	OT-512
Long Sheet kit (Input)	MK-760
Long Sheet kit (Output)	MK-761
3 rd party Interface	MK-737
Relay Unit	RU-510
Stapling Unit	FS-541
Saddle Stitcher kit	SD-510
Punch kit	PK-525
Mount Kit	MK-732
Post inserter kit	PI-502
Press and trim kit	PT-220
Corner forming kit	SF-204
Folding and Punching Unit	FD-503
Booklet making Unit	SD-506
Booklet making Unit	SD-513
Folding kit	FD-504
Trimmer kit	TU-503
Creaser kit	CR-101
Stacking Unit	LS-507
Handcart	LC-502
Perfect Binding Unit	PB-503
Trimmer Unit	TU-510
Creaser kit	CR-102
Trimmer kit	TU-504
Banner kit	MK-764
Job Separator kit	JS-507
Creaser kit upwards	CR-103
Perforation kit Horizontal	PE-101
Perforation kit Vertical	PE-102
Scrap ejection kit	MK-765
GBC Binding Unit	G1
GBC Punching Unit	G2
Max Binding Unit	MB-200
Booklet making Unit	Plockmatic SD-350/500
Booklet making Unit	Plockmatic PSQ-160
Banner Stacking Unit	MPS-130





KONICA MINOLTA

TECHNICAL SPECIFICATIONS

RETHINK PRODUCTION PRINTING

SYSTEM SPECIFICATIONS

Resolution	2,400 x 3,600 equiv. dpi x 8 bit
Paper weight	52 – 450 g/m ²
Duplex unit	Non-stack type; 52 – 450 g/m ²
Paper sizes (max.)	330.2 x 487.7 mm 330.2 x 900 mm (max. duplex) 330.2 x 1300 mm (max. simplex)
Paper input capacity	14,140 sheets
Main unit dimensions (W x D x H)	1,151 x 932 x 1,620 mm
Main unit weight	560 kg

PRODUCTIVITY

AccurioPress C14000	
A4 – max. per minute	140 ppm
A3 – max. per minute	80 ppm
A4 – max. per hour	7,981 pph
AccurioPress C12000	
A4 – max. per minute	120 ppm
A3 – max. per minute	69 ppm
A4 – max. per hour	6,832 pph

- All specifications refer to A4-size paper of 80 g/m² quality.
- The support and availability of the listed specifications and functionalities varies depending on operating systems, applications and network protocols as well as network and system configurations.
- The stated life expectancy of each consumable is based on specific operating conditions such as page coverage for a particular page size (5% coverage of A4). The actual life of each consumable will vary depending on use and other printing variables including page coverage, page size, media type, continuous or intermittent printing, ambient temperature and humidity.
- Some of the product illustrations contain optional accessories.
- Specifications and accessories are based on the information available at the time of printing and are subject to change without notice.
- Konica Minolta does not warrant that any prices or specifications mentioned will be error-free.
- All brand and product names may be registered trademarks or trademarks of their respective holders and are hereby acknowledged.